



J4PRC5150A3E0A

TAG: _____

SUBMITTAL

**12.5 Ton
Oxbox Electric/Electric Rooftop
J4PRC5150A3E0A**

NOTES:
1. VERIFY WEIGHT, CONNECTIONS, AND ALL DIMENSIONS WITH INSTALLER DOCUMENTS BEFORE INSTALLATION

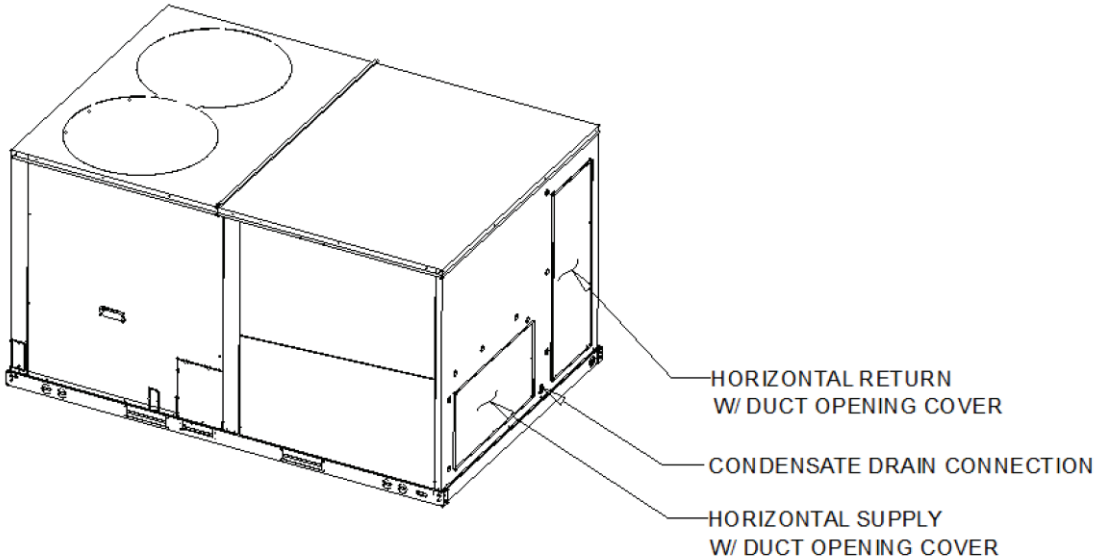

Product Specifications

UNIT OVERVIEW

Model	J4PRC5150A3E0A
Application	Cooling
Unit Size	12.5 Ton

UNIT FEATURES

SupplyFan/Drive/ MotorType	Two speed fan standard motor
----------------------------	------------------------------

UNIT ELECTRICAL

Voltage/phase/hertz	208-230/60/3
---------------------	--------------

CONTROLS

Unit Controls	Electro-mechanical
---------------	--------------------

PRODUCT SPECIFICATIONS

W X H X D

UNIT (IN.)	88 1/4" X 49" X 58 3/4"
------------	-------------------------

CRATED (IN.)	89 1/2" X 49 3/5" X 59 4/5"
--------------	-----------------------------

WEIGHT

Shipping (LBS.)	1246.0
Net (LBS.)	1049.0

Outline Drawing

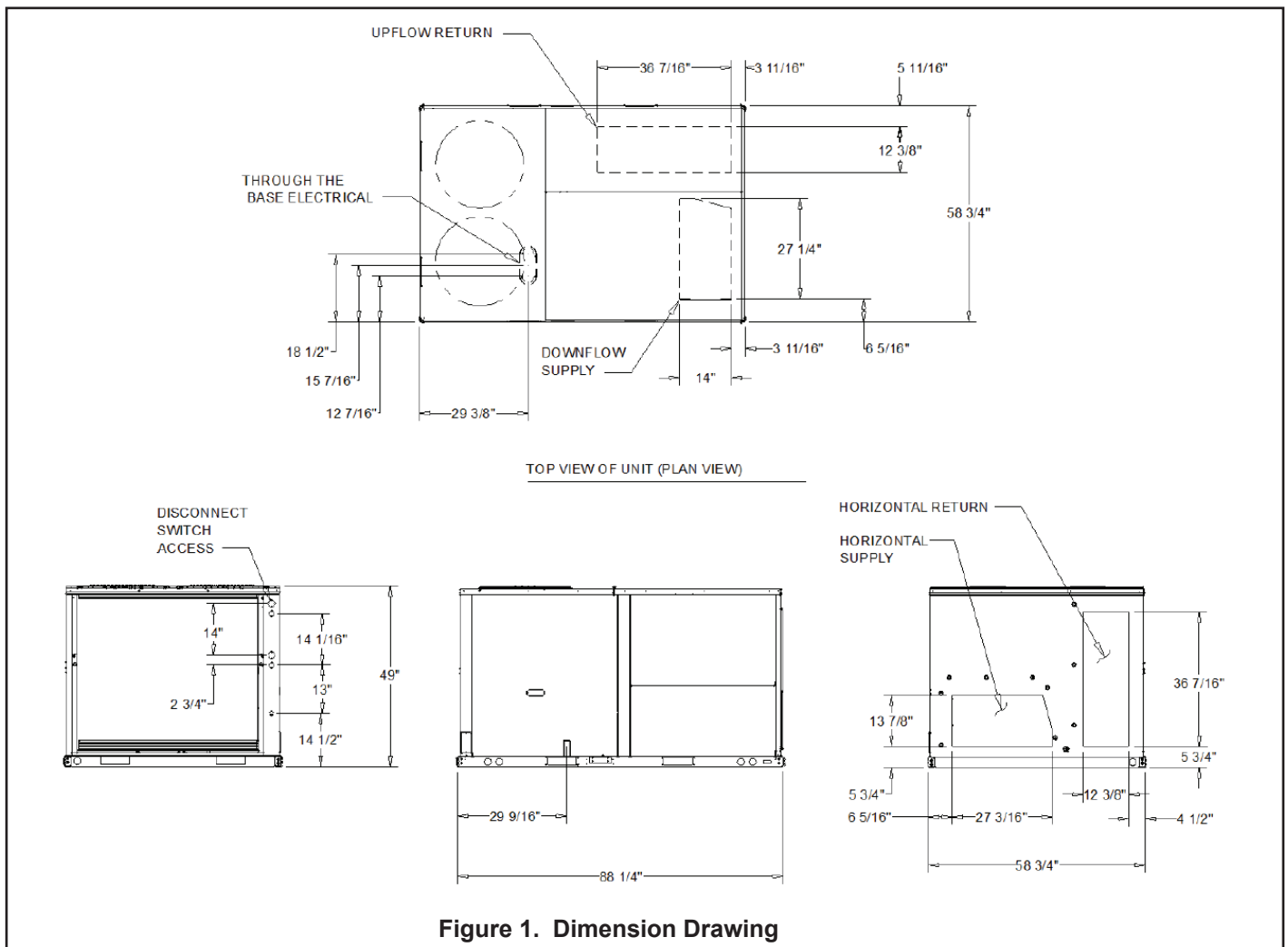

Figure 1. Dimension Drawing

Outline Drawing (Continued...)

Base Unit and Corner Weights

Corner Weights				Center of Gravity	
Ⓐ	Ⓑ	Ⓒ	Ⓓ	E	F
302.0 lb	197.0 lb	208.0 lb	342.0 lb	37 5/8"	33 7/8"

1. All weights are approximate.
2. The actual weight are listed on the unit nameplate.
3. Refer to unit nameplate and installation guide for weights before scheduling transportation and installation of unit.
4. The weight shown represents the typical unit operating weight for the configuration selected. Estimated at $\pm 10\%$ of the nameplate weight.
5. Verify weight, connection, and all dimension with installer documents before installation.
6. Corner weights are given for information only.
7. Net/shipping weight of optional accessories should be added to unit weight when ordering factory or field installed accessories.

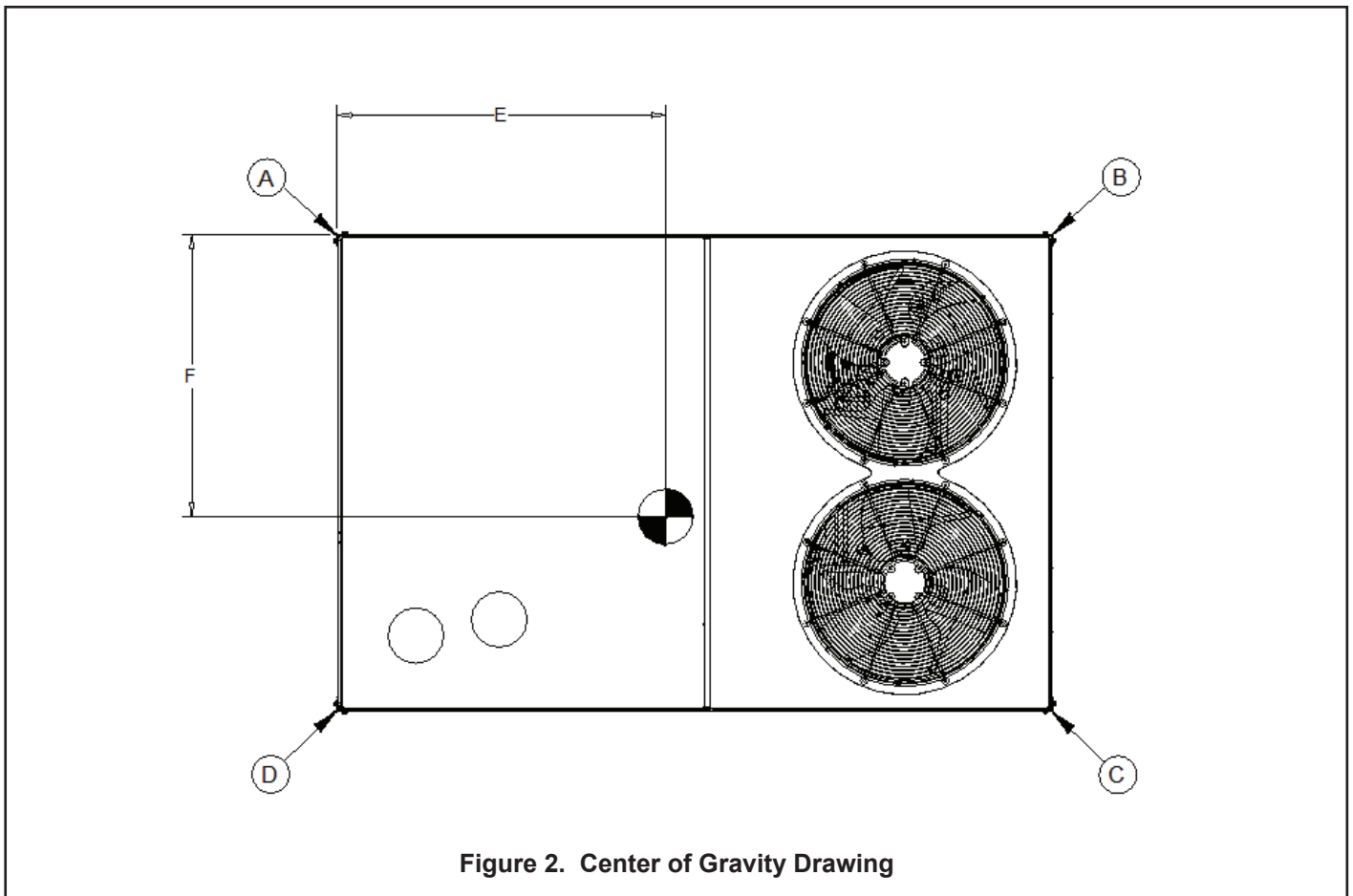

Figure 2. Center of Gravity Drawing

Clearance Requirements

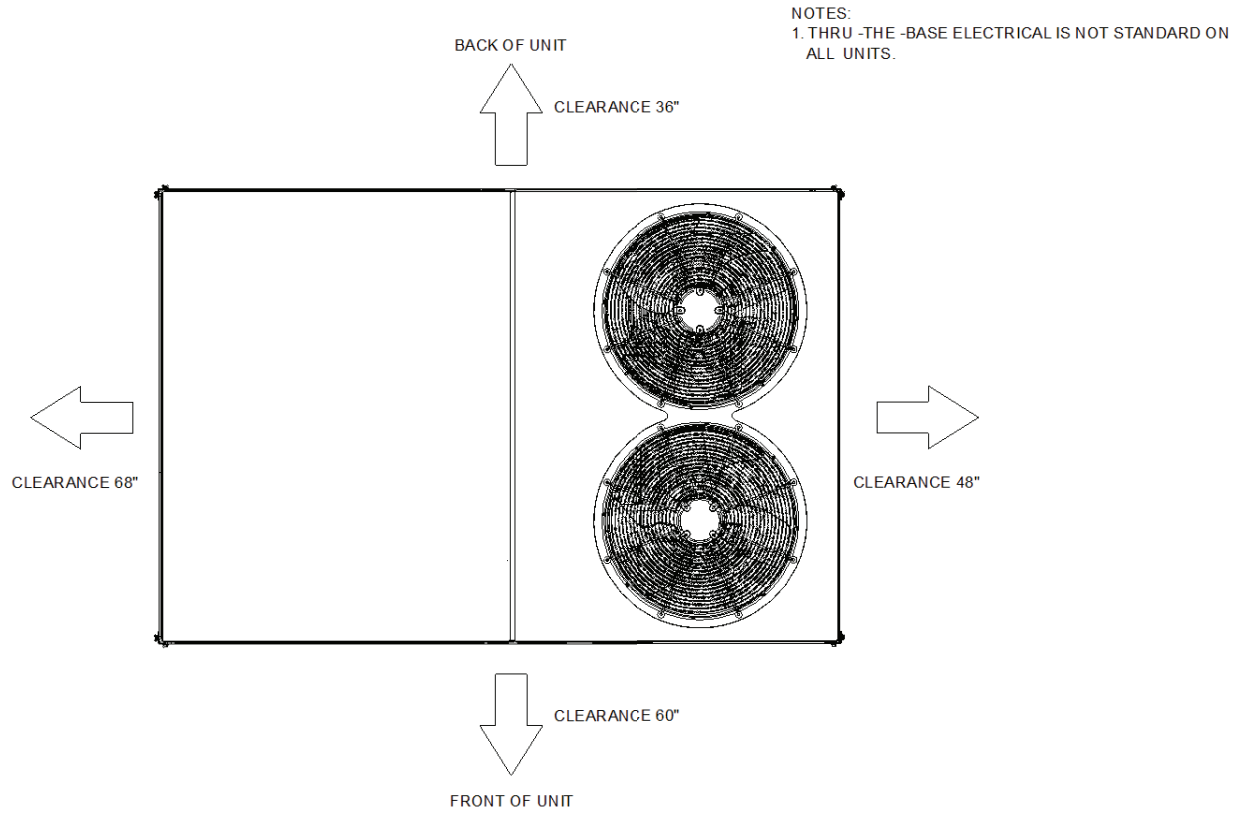

Figure 3. Unit Clearance Drawing

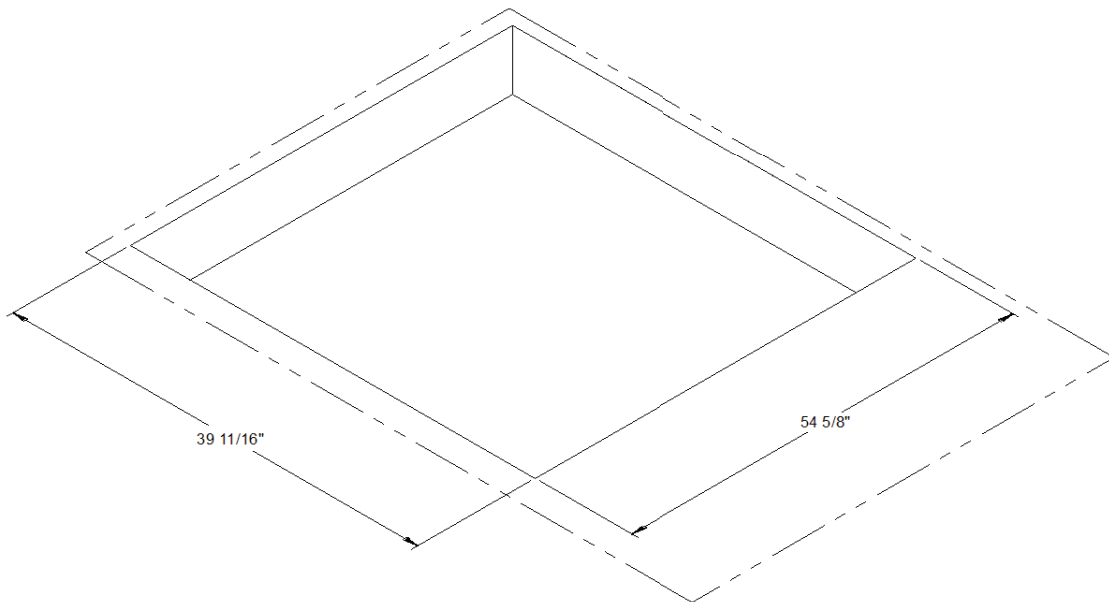

Figure 4. Downflow Clearance Drawing

Mechanical Specifications

General

- Packaged rooftop units cooling, heating capacities, and efficiencies are AHRI Certified within scope of AHRI Standard (I-P) and ANSIZ21.47 and 10 CFR Part 431 pertaining to Commercial Warm Air Furnaces
- Packaged rooftop units are dedicated downflow or horizontal airflow
- Operating range between 125°F and 40°F in cooling standard from the factory
- Factory assembled, internally wired, fully charged with R-410A, and 100 percent run tested to check cooling operation, fan and blower rotation, and control sequence before leaving the factory
- Colored and numbered wiring internal to the unit for simplified identification
- Units cULus listed and labeled, classified in accordance

Casing

- Zinc coated, heavy gauge, galvanized steel
- Weather-resistant baked enamel finish on phosphatized exterior surfaces
- Meets ASTM B117, 672 hour salt spray test
- Removable single side maintenance access panels
- Lifting handles in maintenance access panels (can be removed and reinstalled by removing no more than 11 fasteners while providing a water and air tight seal)
- Exposed vertical panels and top covers in the indoor air section shall be insulated with a 1/2-inch, 1-pound density foil-faced, fire-resistant, permanent, odorless, glass fiber material
- Base of unit shall be insulated with 1/2-inch, 1-pound density, foil-faced, glass fiber material
- Base pan shall have no penetrations within the perimeter of the curb other than the raised 1 1/8-inch high downflow supply/return openings to provide an added water integrity precaution, if the condensate drain backs up
- Downflow units base pan shall have no penetrations within the perimeter of the curb other than the raised 1 1/8-inch high supply/return openings to provide an added water integrity precaution, if the condensate drain backs up
- Base of unit shall have provisions for forklift and crane lifting

Compressors

- All units have direct-drive, hermetic, scroll type compressors with centrifugal type oil pumps
- Suction gas-cooled motor with voltage utilization range of plus or minus 10 percent of unit nameplate voltage

- Internal overloads standard with scroll compressors
- All models have phase monitors and Low and High Pressure Controls as standard

Discharge Line Thermostat

- A bi-metal element discharge line thermostat is installed as a standard option on the discharge line of each system
- Provides extra protection to the compressors against high discharge temperatures in case of loss of charge, extremely high ambient and other conditions which could drive the discharge temperature higher
- Wired in series with high pressure control
- When discharge temperature rises above the protection limit, the bi-metal disc in the thermostat switches to the off position, opening the 24 VAC circuit
- When temperature on the discharge line cools down, the bi-metal disc closes the contactor circuit, providing power to the compressor

Evaporator and Condenser Coils

- Microchannel coils burst tested by manufacturer
- Microchannel evaporator and condenser coils standard on all units
- Coils leak tested to ensure the pressure integrity
- Evaporator coil and condenser coil leak tested to 225 psig and pressure tested to 450 psig
- Sloped condensate drain pans are standard

Filters

Two inch standard filters shall be factory supplied on all units.

Indoor Fan

- Belt driven, FC centrifugal fans with adjustable motor sheaves
- Motors thermally protected
- Indoor fan motors meet the U.S. Energy Policy Act of 1992 (EPACT)

Locking Safety Device

- Pressure switch monitoring allows for lockout in a situation where the switch is opened
- By monitoring the Y input as well as the pressure switches, advanced decision making can be made to identify situations where faults/errors occur

Mechanical Specifications (Continued...)

Phase Monitor

- 3-phase line monitor module
- Protects against phase loss, phase imbalance and phase reversal indication
- Intended to protect compressors from reverse rotation
- Operating input voltage range of 180-632 VAC
- LED indicators for ON and FAULT
- No field adjustments
- Module will automatically reset from a fault condition

Refrigerant Pressure Control

All units include High and Low Pressure Cutouts as standard.

Unit Top

The top cover shall be double hemmed and gasket sealed to prevent water leakage.

Multi-Speed Indoor Fan System

- Incorporates a multi-speed fan control to change the speed of the fan to 70% of full airflow based off of compressor stages

Filters

Two inch standard filters shall be factory supplied on all units.



Oxbox®, endorsed by Trane®, offers simple, affordable residential heating and cooling solutions strong enough to tackle the toughest conditions. For more information visit www.oxboxhvac.com.



The manufacturer has a policy of continuous data improvement and it reserves the right to change design and specifications without notice. We are committed to using environmentally conscious print practices.

The AHRI Certified mark indicates company participation in the AHRI Certification program. For verification of individual certified products, go to ahridirectory.org.

Representative-only illustrations included in this document.

BX-PRQ-J4PRC5150A3E0A-1A 27 Oct 2023

Supersedes (New)