

**OXBOX™**  
A TRANE® BRAND

# INSTALLATION INSTRUCTIONS

## ELECTRIC HEATER ACCESSORY

JAYHTR1P05BKRAA JAYHTR1P08BKRAA JAYHTR1P10BKRAA  
JAYHTR1P15BKRAA JAYHTR1P20BKRAA

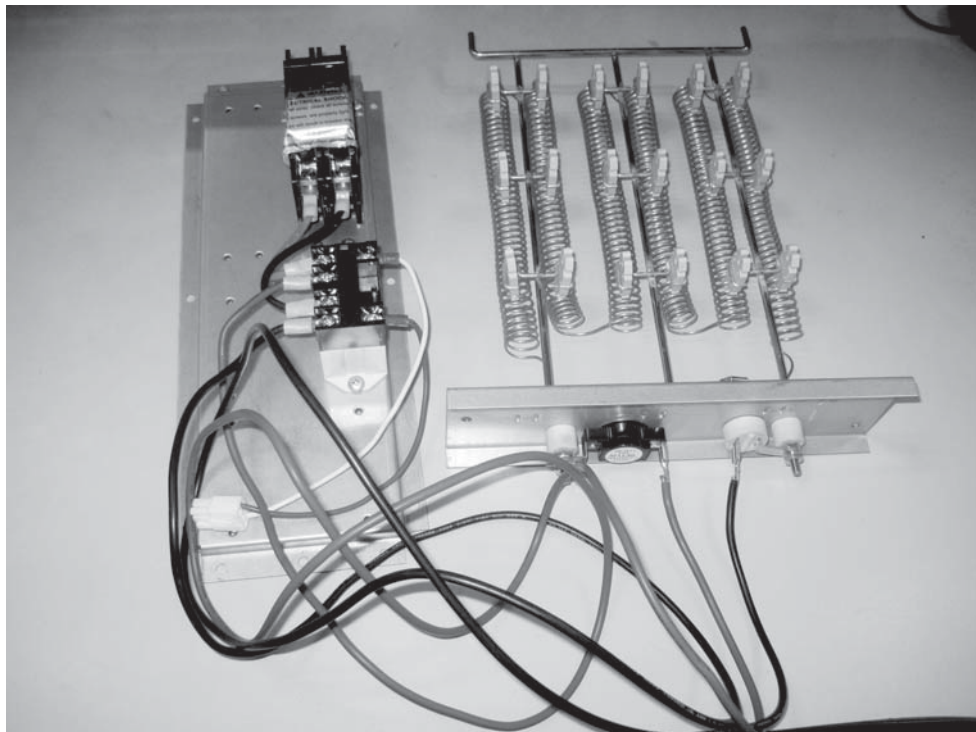

RECOGNIZE THIS SYMBOL AS AN INDICATION OF IMPORTANT SAFETY INFORMATION

### WARNING

These instructions are intended as an aid to qualified licensed service personnel for proper installation, adjustment and operation of this unit. Read these instructions thoroughly before attempting installation or operation. Failure to follow these instructions may result in improper installation, adjustment, service or maintenance possibly resulting in fire, electrical shock, property damage, personal injury or death.

**DO NOT DESTROY THIS MANUAL**

Please read carefully and keep in a safe place for future reference by a serviceman.

## CONTENT

1. INSPECTION.....	3
2. IMPORTANT.....	3
3. GENERAL.....	3
4. COMPONENT LOCATION.....	4
5. INSTALLATION.....	4
6. SPECIFICATION.....	10
7. ELECTRIC DIAGRAM(208/230-1-60).....	11

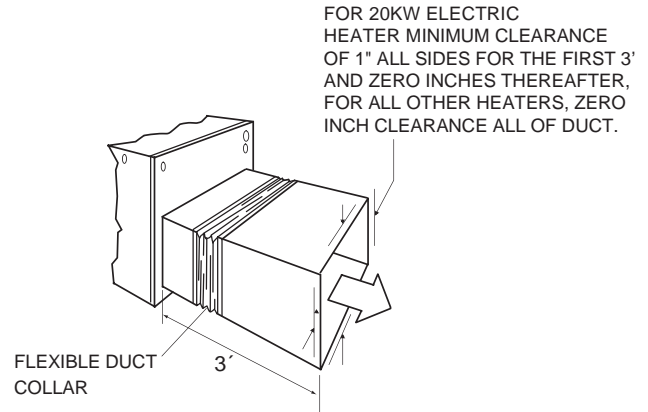

**Fig.1 CLEARANCES**

### 1. INSPECTION

As soon as unit is received, it should be inspected and noted for possible shipping damage during transportation. It is carrier's responsibility to cover the cost of shipping damage. Manufacturer or distributor will not accept the claims from dealer for any transportation damage.

### 2. IMPORTANT

The equipment described in this instruction should be installed by trained and experienced service personnel.

A separate power supply line must be provided for use with optional electric heater. **DO NOT** try to connect electric heater with rooftop unit to a single power supply line.

### 3. GENERAL

Electric heaters should be installed only in designated rooftop units. All electric heaters and their accessories are designed for applications used for cooling with electric heaters and heat pump with electric heaters. This instruction covers the installation of the following electric heaters:  
 JAYHTR1P05BKRAA JAYHTR1P08BKRAA  
 JAYHTR1P10BKRAA JAYHTR1P15BKRAA  
 JAYHTR1P20BKRAA

	NOTE
The electric heat accessory should be installed before the supply air duct is attached to the supply air opening flanges.	

*Table 1: Unit Clearance*

Direction	Distance (in.)	Direction	Distance (in.)
Top <sup>1</sup>	60	Right	12
Front	30	Left	12
Rear	18 <sup>2</sup>	Bottom <sup>3</sup>	0

- Duct clearance: 1 inch clearance for all sides of air supply duct.
1. Units must be installed outdoors. Over hanging structure or shrubs should not obscure condenser air discharge outlet.
  2. Units may be installed on combustible floors made from wood or class A, B or C roof covering materials.

## 4. COMPONENT LOCATION

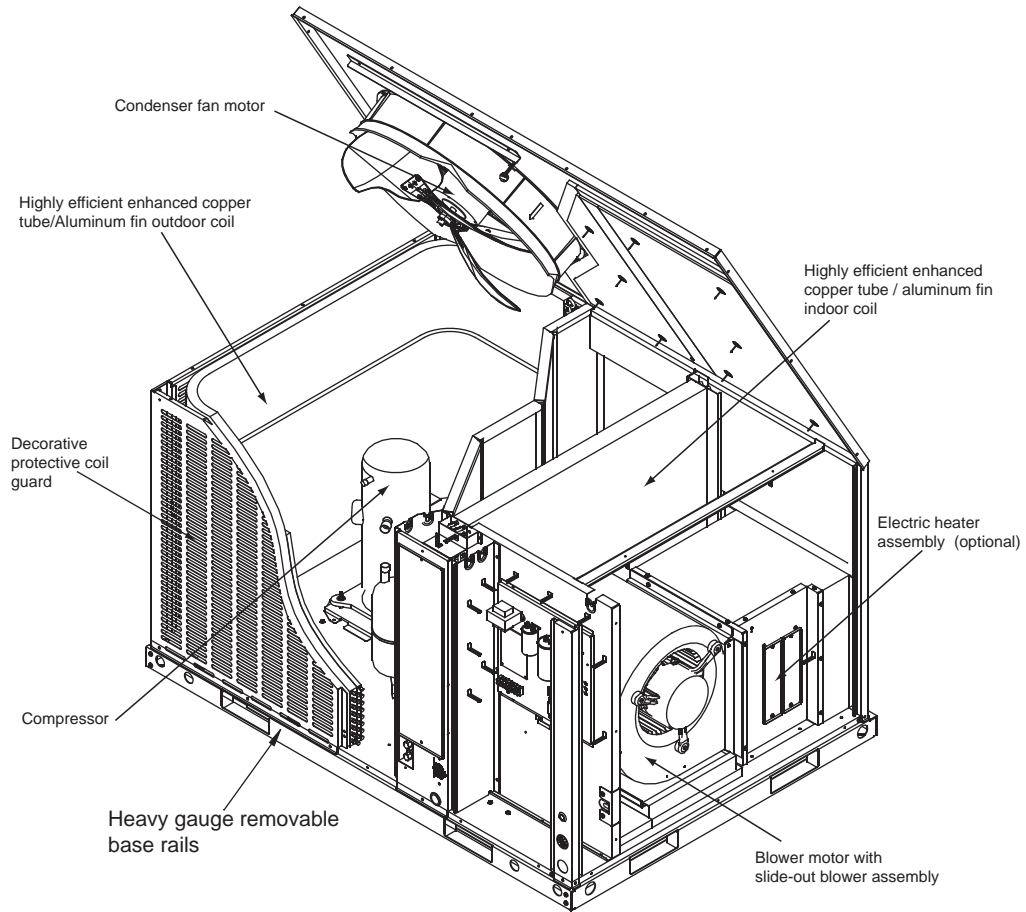

\* The above figure for reference purpose only.

## 5. INSTALLATION

Install the electric heater accessory as follows:

*FIG.A*



1. Disconnect all electric power supplies to the unit.

2. Unscrew all screws around the panel. Remove the panel of the rooftop unit.(See Fig. A & B)

*FIG.B*

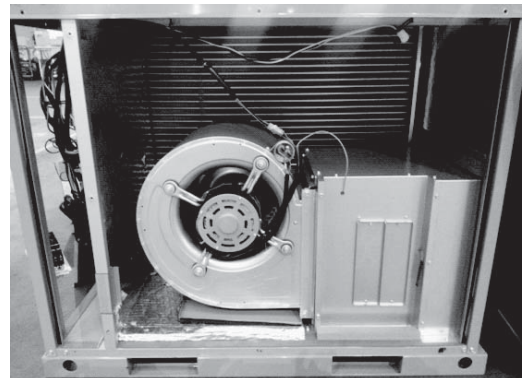
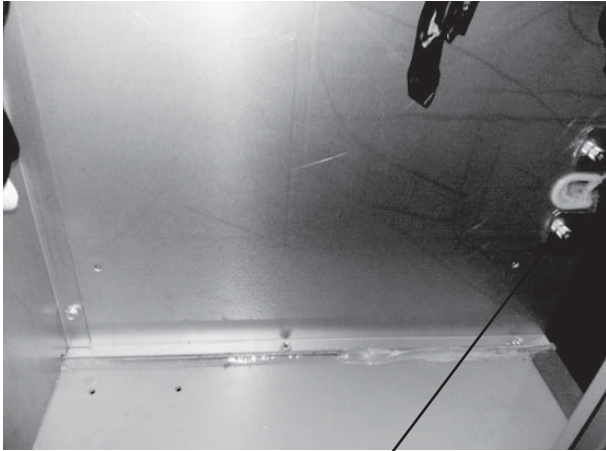
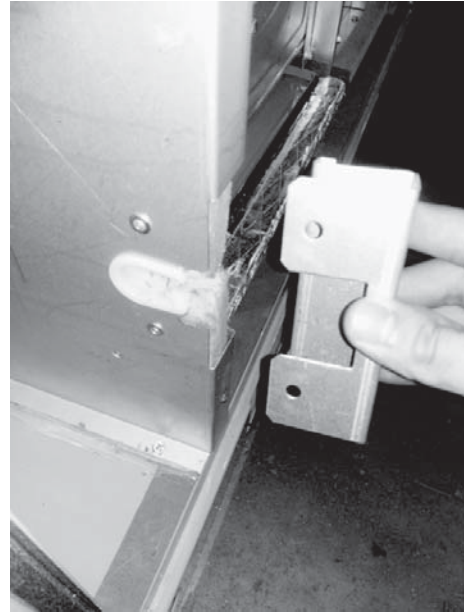

FIG.C



3. Remove electric heat kit wiring panel by removing two screws. (See Fig. C&D)

FIG.D



4. From blower plenum, remove two screws (four screws for JAYHTR1P15BKRAA/JAYHTR1P20BKRAA) and cover plate that you can discard after heater is installed . (See Fig. E or F)

FIG.E (for JAYHTR1P05BKRAA/  
JAYHTR1P08BKRAA/JAYHTR1P10BKRAA)

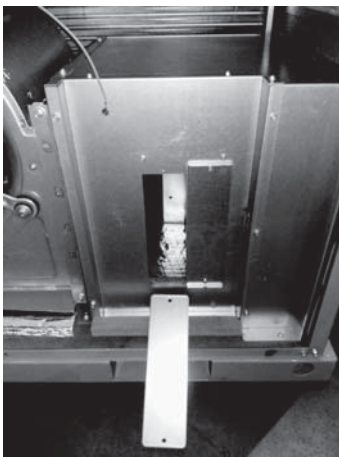
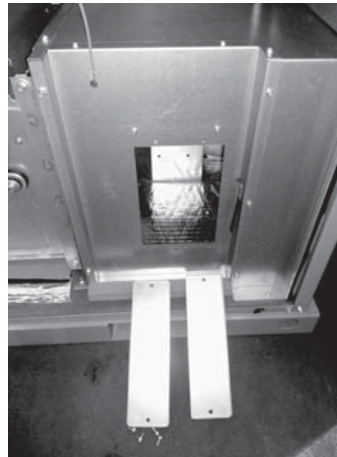
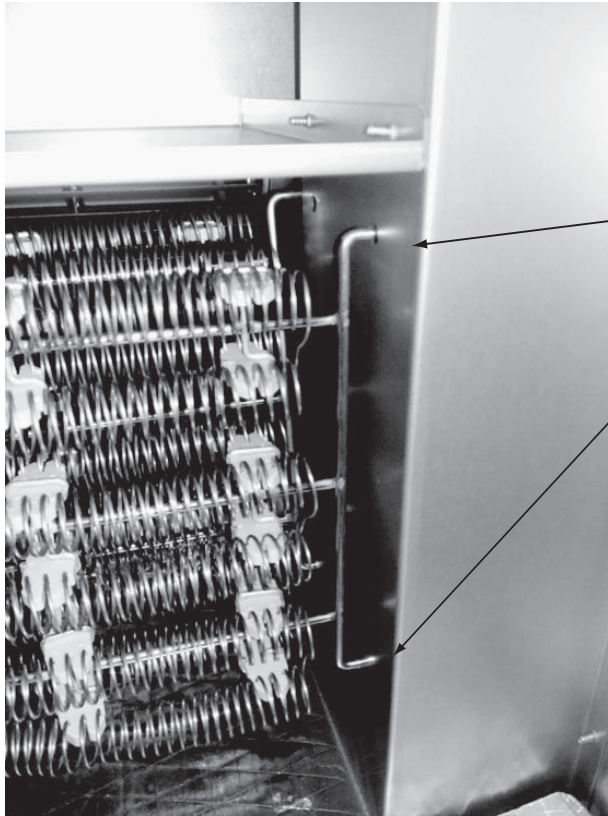

FIG.F (JAYHTR1P15BKRAA/  
JAYHTR1P20BKRAA)





*FIG.G*



5. Slide electric heater into the slot.  
Ensure heater support rod be placed into the  
hole of blower compartment. (See Fig. G)

Place heater rod into the hole  
of blower compartment

6. Carefully align the plate of electric heat kit with the holes of the blower plenum, use the screws removed in step 4 and Accessory pouch, then tighten the screws to hold the electric heat kit to the plenum. (See Fig. H or I)

*FIG.H (for 24/30/36K)*



*FIG.I (for 42/48/60K)*



7. Tighten wires with clips in the bar, and bundle loose wires with fastening belt . (See Fig. J&K)

FIG.J



Clip

FIG.K

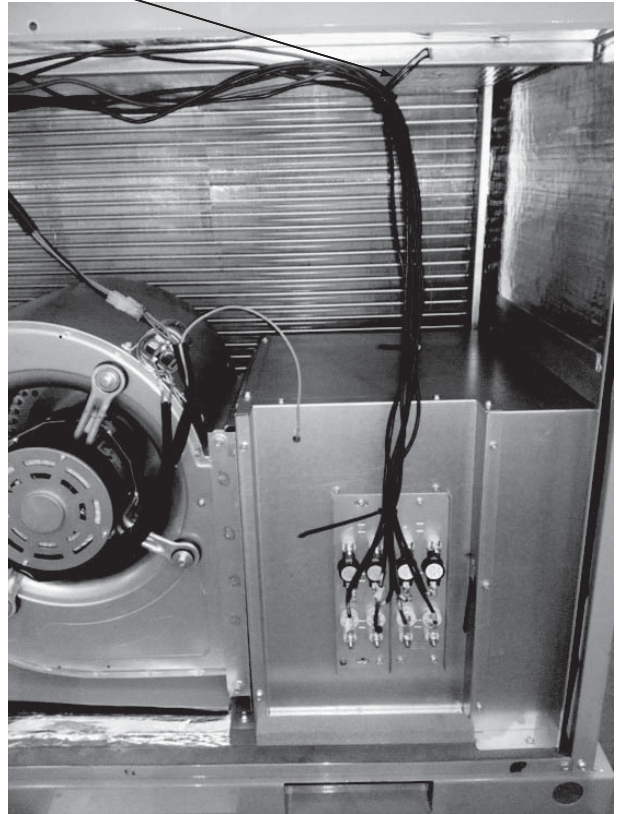

8. Use the screws in Step 3 to reinstall wiring panel . (See Fig. L)

FIG.L

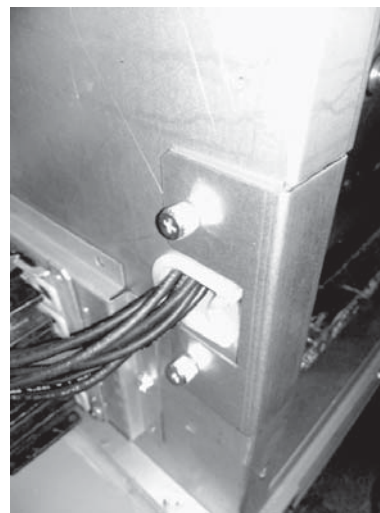

9. Secure electric heat kit electric control installation board with two screws provided. (See Fig. M or N)

*FIG.M (for 24/30/36K)*

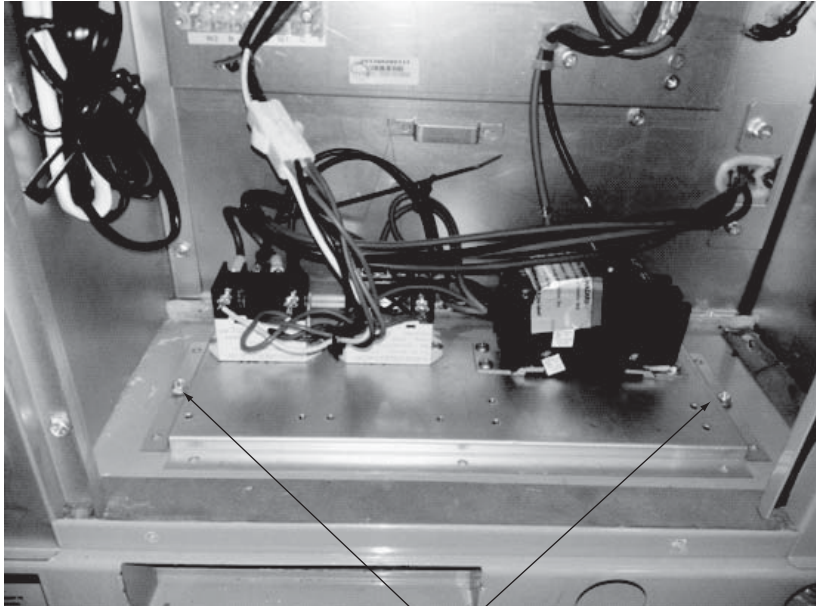

screws

*FIG.N (for 42/48/60K)*

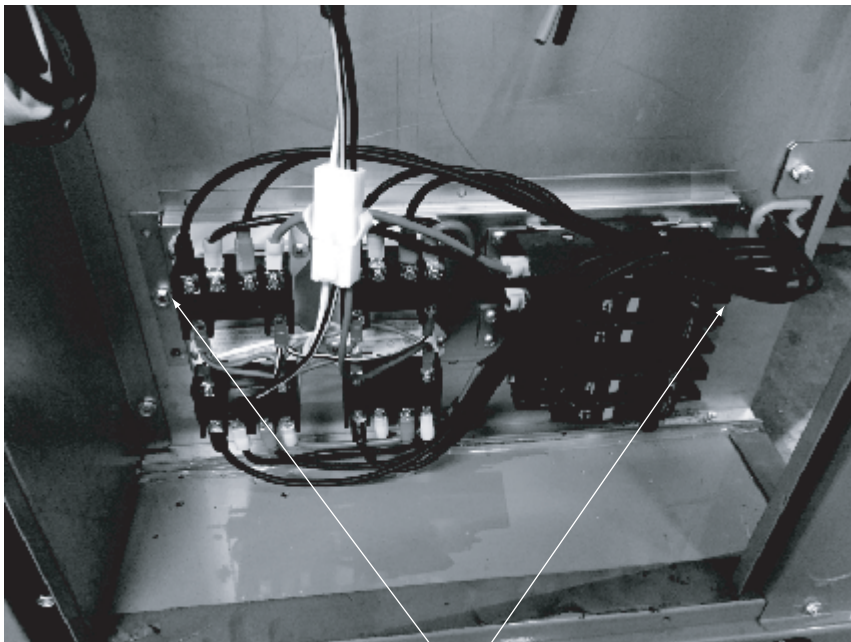

screws

10. High Voltage Supply for heater kit must be routed through separate H.V. Knock-out, See Fig. A for location.
11. Carefully inspect all wire connections and secure any loose wiring.
12. Remount the panel.
13. Restore all power supply.



## **WARNING**

### **FIRE, ELECTRICAL SHOCK, HAZARD**

After re-connecting all wires, check all screws of breaker and make sure all screws are properly tightened.

Failure to do so will result in breaker malfunction, fire, death, personal injury or property damage.



## 6. SPECIFICATION

**Table 6-1: Electric Heat Circuit Ratings**

Unit Model	Volt	Compressors (each)			OD Fan Motors (each)	Supply Blower Motor	Unit Circuit		Heater Circuit							
		RLA	LRA	MCC			FLA	FLA	MCA	Max Fuse/Breaker Size	Model	kW	Stages	Amps	MCA	MOP
J4PH4024A1000AA	208/230-1-60								JAYHTR1P05BKRAA	3.8/5	1	18.1/20.8	23/26	25/30		
		8.45A	34.8A	14.87A	0.68A	2.46A	13.7	20	JAYHTR1P08BKRAA	5.6/7.5	1	27.1/31.3	34/39	35/40		
									JAYHTR1P10BKRAA	7.5/10	1	36.1/41.7	45/52	45/60		
J4PH4030A1000AA	208/230-1-60								JAYHTR1P05BKRAA	3.8/5	1	18.1/20.8	23/26	25/30		
		12.0A	59.93A	21.7A	1.0A	4.1A	20.1	30	JAYHTR1P08BKRAA	5.6/7.5	1	27.1/31.3	34/39	35/40		
									JAYHTR1P10BKRAA	7.5/10	1	36.1/41.7	45/52	45/60		
J4PH4036A1000AA	208/230-1-60								JAYHTR1P15BKRAA	11.3/15	2	54.2/62.5	68/78	70/80		
		13.0A	75A	22.9A	1.0A	4.1A	21.4	30	JAYHTR1P05BKRAA	3.8/5	1	18.1/20.8	23/26	25/30		
									JAYHTR1P08BKRAA	5.6/7.5	1	27.1/31.3	34/39	35/40		
									JAYHTR1P10BKRAA	7.5/10	1	36.1/41.7	45/52	45/60		
J4PH4042A1000AA	208/230-1-60								JAYHTR1P15BKRAA	11.3/15	2	54.2/62.5	68/78	70/80		
		15.2A	112.3A	24.8A	1.67A	2.8A	23.5	35	JAYHTR1P20BKRAA	15/20	2	72.2/83.3	90/104	90/110		
									JAYHTR1P05BKRAA	3.8/5	1	18.1/20.8	23/26	25/30		
									JAYHTR1P08BKRAA	5.6/7.5	1	27.1/31.3	34/39	35/40		
									JAYHTR1P10BKRAA	7.5/10	1	36.1/41.7	45/52	45/60		
J4PH4048A1000AA	208/230-1-60								JAYHTR1P15BKRAA	11.3/15	2	54.2/62.5	68/78	70/80		
		17.3A	108A	28.5A	1.67A	3.6A	26.9	40	JAYHTR1P20BKRAA	15/20	2	72.2/83.3	90/104	90/110		
									JAYHTR1P05BKRAA	3.8/5	1	18.1/20.8	23/26	25/30		
									JAYHTR1P08BKRAA	5.6/7.5	1	27.1/31.3	34/39	35/40		
									JAYHTR1P10BKRAA	7.5/10	1	36.1/41.7	45/52	45/60		
J4PH4060A1000AA	208/230-1-60								JAYHTR1P15BKRAA	11.3/15	2	54.2/62.5	68/78	70/80		
		21.5A	125A	34.3A	1.67A	6.0A	34.6	50	JAYHTR1P20BKRAA	15/20	2	72.2/83.3	90/104	90/110		
									JAYHTR1P05BKRAA	3.8/5	1	18.1/20.8	23/26	25/30		
									JAYHTR1P08BKRAA	5.6/7.5	1	27.1/31.3	34/39	35/40		
									JAYHTR1P10BKRAA	7.5/10	1	36.1/41.7	45/52	45/60		
									JAYHTR1P15BKRAA	11.3/15	2	54.2/62.5	68/78	70/80		
									JAYHTR1P20BKRAA	15/20	2	72.2/83.3	90/104	90/110		

# 7. ELECTRIC DIAGRAM(208/230-1-60)

